

Tilt sensors

Low cost, USB Series

Main features

- High performance, 2-Axis tilt sensors.
- Low cost, small size.
- Build around proven iMEMS technology.
- USB 2.0 interface.

Applications

- Laser levelling
- Equipment monitoring
- Instrumentation



USB Series

The USB Series of low cost tilt sensors offers an easy way to measure inclination from $\pm 40^\circ$ or $\pm 2G$ acceleration over a short distance. Available in different configurations, they target applications from levelling to equipment monitoring. The USB Series can be fitted in any test setup where **level** or **acceleration** has to be measured. Build around the proven iMEMS technology, the USB Series of tilt sensors offer performances comparable to traditional tilt sensors but at lower cost.

The USB Series of sensors has been build to be of easy of use. Powered directly from the USB port, it doesn't require any other wiring. Measurements are read using a simple communication protocol. The sensor returns a 12 bits digital value of the internal iMEMS reading. This prevents the need to interface to an external A/D or other data acquisition hardware. The PC software just need to start the acquisition mode and the sensors returns a sample every 0.01 seconds.

When connected to a computer, the sensor appears as a new serial port in Windows. Your application simply needs to open this port to communicate with the sensor. Available commands are define in application note AN-03028-01.

The USB Series comes with a standard type A USB male plug at the end of 6 feet of cable.

Principle of operation

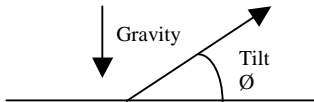

Tilt sensors output voltage varies in accordance with inclination relative to gravity. When sensor is parallel to the earth's surface, output tilt in degree is calculated as follows:

$$\theta = \text{SIN}^{-1} (\Delta V_{\text{out}} / 174\text{mV})$$

Refer to application note AN-03028-01 for details about serial communication.

Specifications	Typical
Performance	
Linear angular range (°)	± 40
Acceleration range (g)	± 2
Sensitivity (mV/g)	± 174
Transversal Sensitivity (% Span)	± 2
Non-Linearity (% FS)	± 0.2
Alignment Error (deg)	± 1
Bandwidth (Hz)	10 - 100
Environment	
Operating Temp Range (°C)	0 to 70°C
Electrical	
Supply Voltage (Volts)	
Power by USB connector:	+ 3.3
Supply Current (mA)	4
Physical	
Size (In)	2.61 x 1.96 x 0.78
(mm)	66.3 x 50 x 20

Mechanical

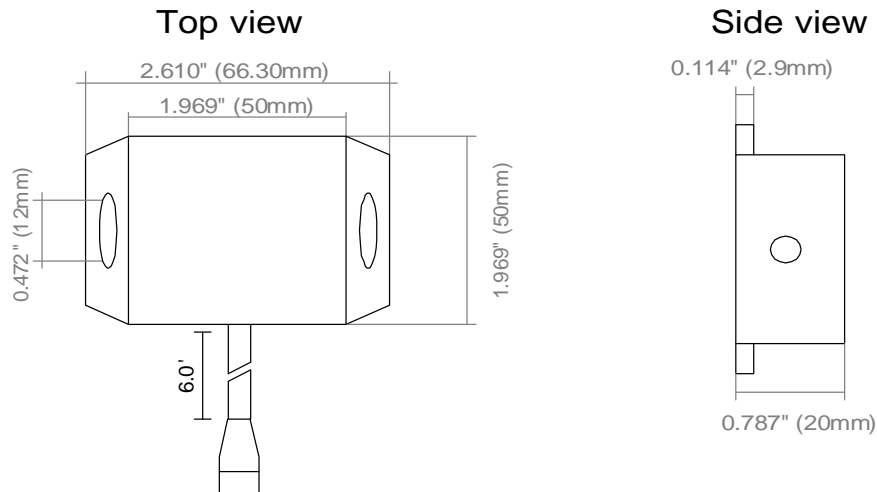

Ordering Information

Part number: GS311USB (Black ABS plastic box)