

Tilt switches

Low cost, DG Series

- High performance, 1-Axis and 2-Axis accelerometer switches.
- Low cost.
- Build around proven iMEMS technology.
- Digital and serial outputs available.

Applications

- Protection system
- Monitoring equipment
- Instrumentation



DG Series

The DG Series of low cost tilt switches offer an easy way to activate alarms or relays upon measurement of a specific angle. Available in 1-Axis or 2-Axis configurations, DG Series targets applications from protection system to instrumentation. Sensors can be fit in any monitoring equipment where critical angles are to be detected. Build around iMEMS technology, the DG Series of tilt switches offer performance comparable to traditional tilt sensors but at a lower cost.

The DG Series offers 2 or 4 open collector outputs that are angle activated. Depending on the model used, outputs are activated, when a specific angle is reached. If the sensor tilts on one side for more than the trigger point, the corresponding output is activated. The four outputs are Pitch A, Pitch B, Roll A, and Roll B. Available as options, the DG series offers an RS-232 serial communication link (TTL Level). Angle measurement can then be read using a simple communication protocol.

The DG Series is offered with a 4-pin or 8-pin connector depending on selected model. The shielded cable prevents noise from affecting measurement outputs. High input voltage range is available to be compatible with most 42V and higher application.

Mechanical

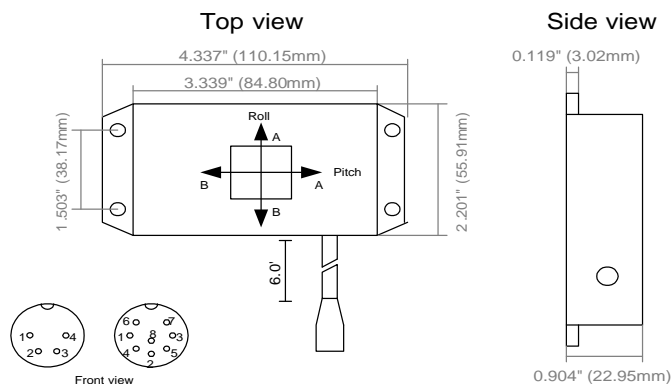

Principle of operation

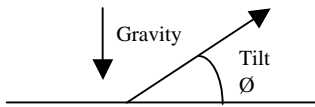

Tilt switches, measure inclination angle relative to gravity. When a side of the sensor is tilted for more than the specified threshold, the corresponding output is activated. Angle in degree is calculated as follow:

$$\varnothing = \text{SIN}^{-1} (\text{Vout} / 1.841)$$

Refer to application note AN-03028-01 for details about serial communication.

Specifications	All models
Performance	
Measurement range (g)	± 2
Sensitivity (mV/g)	174 ± 26
Transversal Sensitivity (% Span)	± 2
Non-Linearity (% FS)	± 0.2
Alignment Error (deg)	± 1
Bandwidth (Hz)	DC - 100
Environment	
Operating Temp Range (°C)	0 to 70°C
Electrical	
Supply Voltage (Volts)	
L: suffix	+ 3.3 to 16
H: suffix	+ 10 to 60
Supply Current (mA)	3.5
Drain Current (mA) / Output	220
Physical	
Size (In)	3.3 x 2.2 x 0.96
(mm)	85 x 56 x 25

Connectors

Pin	Color	GS311DGv1a ¹	GS311DGv2a ¹	GS311DGv3a ²	GS311DGv3a-Cy ²
1	Black	Ground	Ground	Ground	Ground
2	White	Pitch A	Roll A	Pitch A	Pitch A
3	Red	Power In	Power In	Power In	Power In
4	Green	Pitch B	Roll B	Pitch B	Pitch B
5	Orange			Roll A	Roll A
6	Blue			NC	TX output
7	White/Black			NC	RX input
8	Red/Black			Roll B	Roll B

1-Singatron Enterprises YE-1154

2-Singatron Enterprises YE-1158A

Ordering Information

GS311DGvxa(-Cy)

v = Input voltage

x = Trip outputs

a = Trip angle selection

L=Low voltage

1=Pitch A-B

1= 5°

5= 25°

H=High voltage

2=Roll A-B

2= 10°

6= 30°

3=Pitch A-B, Roll A-B

3= 15°

7= 35°

4= 20°

8= 40°

Communication options (L3, H3 only)

-C1 = RS-232

Addict Technologies

324 St-Paul

Le Gardeur, Québec

Canada J5Z 4H9

Voice: (450) 585-2284

Email: support@addict-technologies.com

www.addict-technologies.com